



TECHNICAL DATA SHEET SLIDING TELESKOPIC FIRE GATES SINGLE LEAF SGS-T EI 60

Technical data sheets serve to determine the basic space requirements of sliding telescopic fire gates. Other dimensions or atypical demands can be solved upon request.

SGS-T (2+0) EI 60

MOTOR

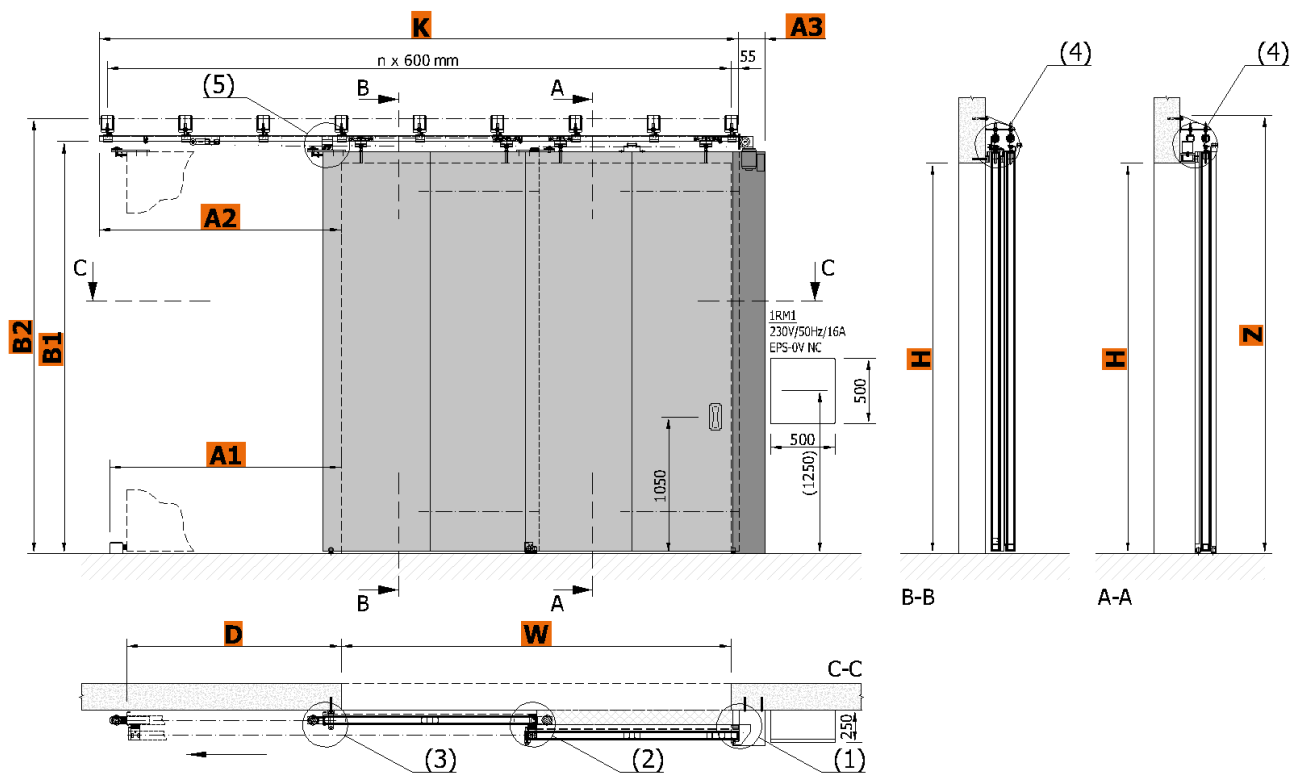

W	opening width [mm]	H	opening height [mm]
D	gate range = $W/2 + \text{min. } 150 \text{ mm}$		
A1	floor stop = $D + 130 \text{ mm}$		
A2	overlap from edge of opening = $D + \text{min. } 118 \text{ mm}$		
A3	overlap from edge of opening = 205 mm		
K	length of rail = $A2 + W + 55 \text{ mm}$		
B1	height of rail from floor = $(H \leq 3,5 \text{ m}) \Rightarrow H + 165 \text{ mm}; (H > 3,5 \text{ m}) \Rightarrow H + 175 \text{ mm}$		
B2	axis of fixing system = $(H \leq 3,5 \text{ m}) \Rightarrow H + 340 \text{ mm}; (H > 3,5 \text{ m}) \Rightarrow H + 405 \text{ mm}$		
Z	overall height without cover = $(H \leq 3,5 \text{ m}) \Rightarrow H + 365 \text{ mm}; (H > 3,5 \text{ m}) \Rightarrow H + 430 \text{ mm}$		

Average weight of gate leaf = 50 kg/m²

TECHNICAL DATA SHEET SGS-T (2+0) EI 60 MOTOR



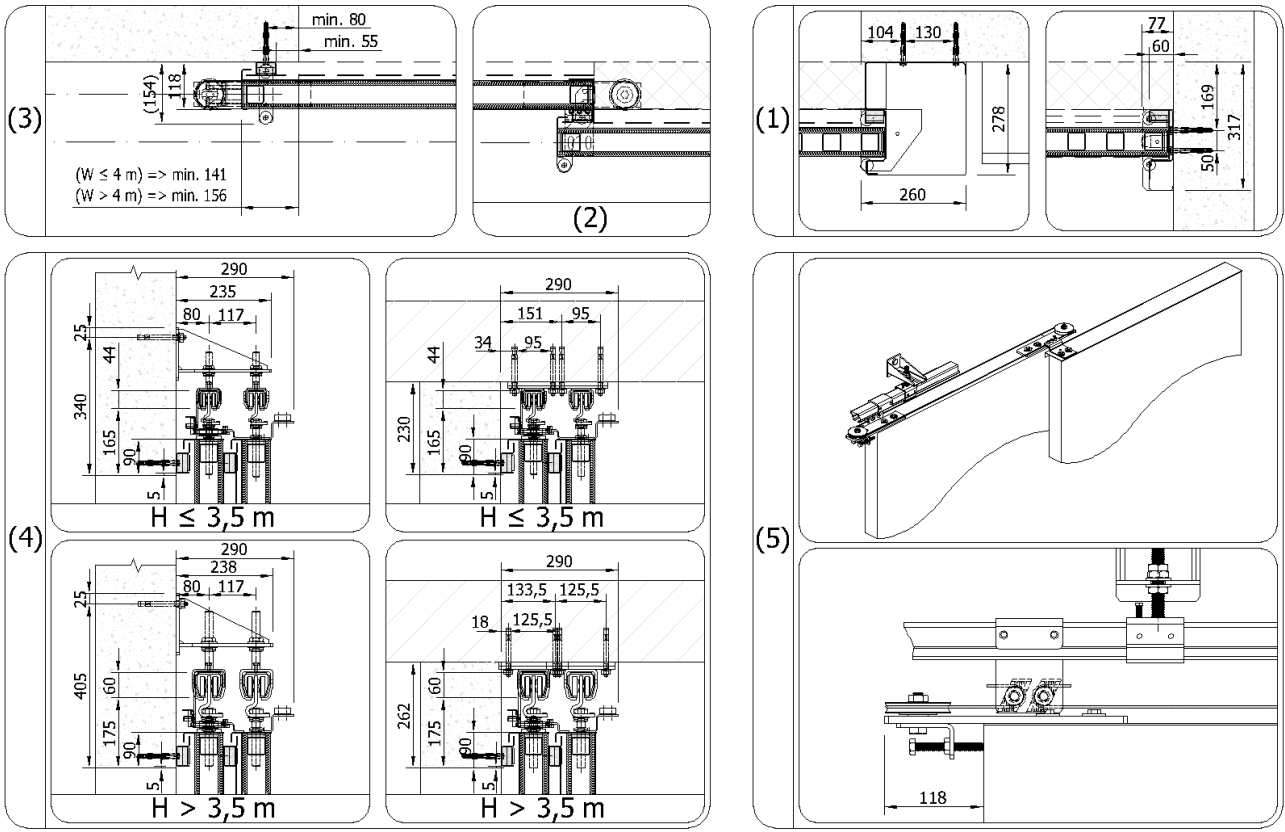

Minimum required dimensions of steel structure

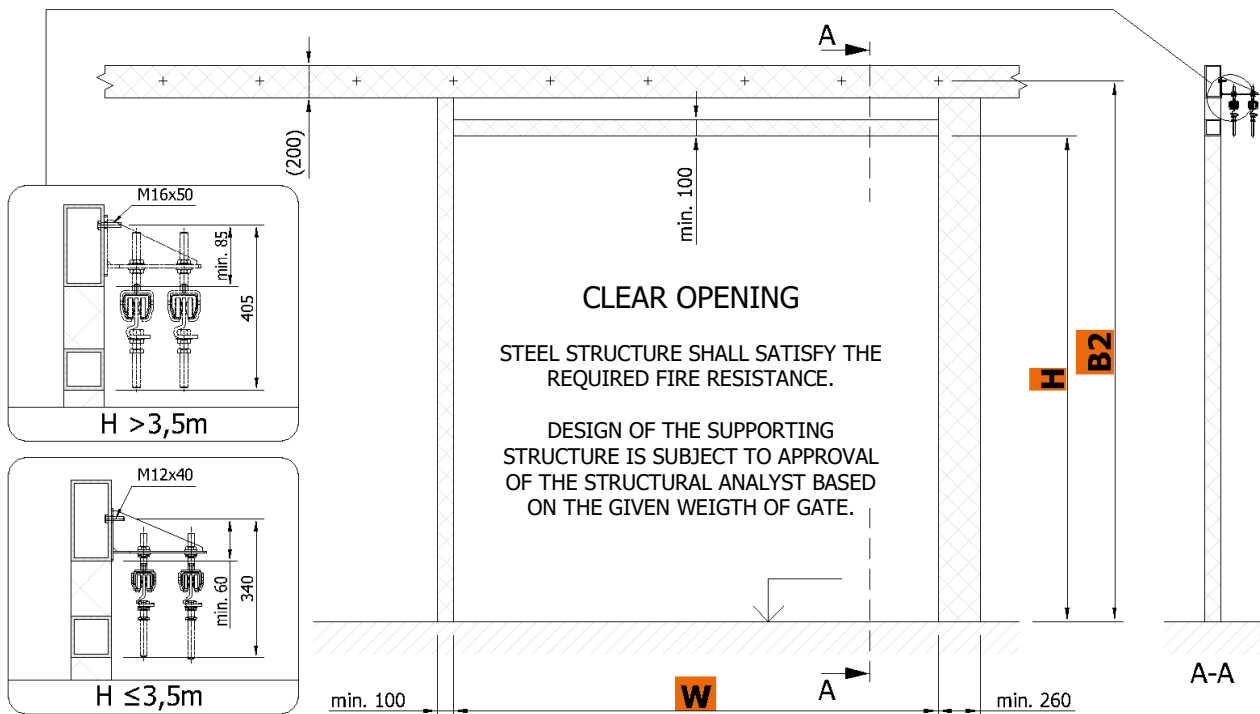

Construction readiness of the opening is secured by the customer according to the requirements of the contractor and depending on the type of jamb and lintel of the opening.

Anchor brackets can be fixed with anchor bolts (concrete, solid brick), or to anchor targets with bolts through wall (foam silicate, gas silicate or breeze (hollow) blocks), or to prepared steel structure with appropriate fire resistance (plasterboard wall, sandwich panels etc.). It is necessary to respect the flatness of the wall and the floor with a tolerance of max. 3 mm/m.

Technical changes reserved.

Would you like to know more? Contact us.

Somati system s.r.o., Jihlavská 510/2c, 664 41 Troubsko
 IČ: 29260159, DIČ: CZ29260159
 www.somati-system.cz